

EASYRAIL 4.00



Installation Manual Easy-Rail 4.00

Revision/Date: 6/01-03-2016

VOLKMANN & ROSSBACH GmbH & Co. KG
Hohe Straße 9 - 17
56410 Montabaur

Content

1	General information.....	1
1.1	Preliminary notes	1
1.2	Manufacturer.....	1
1.3	Intended Use	1
1.4	Storage and Transport	1
2	Technical data.....	2
3	Installation guidelines	2
3.1	General remarks.....	2
3.1.1	Place of installation	2
3.1.2	Limits of installation	2
3.1.3	Grounding	3
3.1.4	Minimum installation length.....	4
3.1.5	Permissible assembly temperatures.....	4
3.1.6	Requirements for installation personnel	4
3.1.7	Control of the delivery / Labeling of the parts	4
3.1.8	Cable clarification	4
3.1.9	Traffic Safety	4
3.1.10	Personal protective gear or equipment	5
3.2	Installation	5
3.2.1	Installation heights in differing situations	5
3.2.2	Posts.....	5
3.2.3	Fittings.....	6
3.2.4	Support brackets	6
3.2.5	Beams	7
3.3	Deviations from the basic construction.....	7
3.3.1	Fitted pieces.....	7
3.3.2	Use of radii	8
3.3.3	Use of deviations	8
3.3.4	Additional attachments	8
3.4	Controls, self-monitoring reports, installation tolerances.	9
3.5	Repair, inspection and maintenance.....	9
3.6	Reusability of guard rail parts.....	10
3.7	Disposal / Recycling	11
3.8	Data for toxic substances	11
3.9	Miscellaneous information	11

Content

Appendices:

Appendix 1	Parts Lists
Appendix 2	Marking of Parts
Appendix 3	System and Assembly Drawings
Appendix 4	Assembly Details
Appendix 5	Form Self-Monitoring (Internal Quality Control)

1 General information

1.1 Preliminary notes

The Easy Rail 4.00 restraint system is made up primarily of the following elements:

- Guard rail beam profile A or B
- Posts C-100-60-25
- Support brackets
- Bolting material (see the parts list in Appendix 1)

which are then fitted together into a continuous stretch of guard rail.

In order that the declared performance of the original test report (ITT) can be achieved, assembly and installation are to be fulfilled exactly according to following requirements. In the case that there is a deviation from these requirements in the assembly and installation without consulting with the manufacturer, the liability for the defects of the building product is transferred from the manufacturer to the installation contractor.

In the case that the installation takes place in Germany, then it is independent of the surrounding temperature at the time of installation (except in the case of repairs). In regions where the minimum outside air temperature T_{min} according to EN 1991-1-5/NA is under -24°C , then installation is only to take place with the written consent of the manufacturer.

1.2 Manufacturer

VOLKMANN & ROSSBACH GmbH & Co. KG

Hohe Straße 9 – 17

56410 Montabaur, Germany

Telephone: +49 2602 135-0

Fax: +49 2602 135-270

1.3 Intended Use

This product is a vehicle restraint system for installation on roads. Its purpose is the protection of non-involved persons or areas besides the road in need of protection. It also serves to protect oncoming traffic on a dual-lane road as well as protecting vehicle occupants in the case the vehicle leaves the roadway.

1.4 Storage and Transport

All guard rail construction parts are to be stored and handled in a technically correct manner. They are to be protected from dirt, corrosion and damage. Construction parts which are laid out for installation should be used within a short period of time. When shipping, the cargo must be securely fastened so that it does not shift. The personnel doing the shipping should be outfitted with personal protection equipment according to national regulations.

2 Technical data

Containment Level	N2
Class of Working Width	W4 ($W \leq 1.3\text{m}$)
Dynamic Deflection	$D_N = 0.9\text{ m}$
Installation Length	80 m
ASI value	A
System Height	75 cm +/- 3 cm tolerance
Driving depth	approx. 100 cm
System Width	21.6 cm (A-profile) or 20.6 cm (B-profile)
Post Center	4.00 m
Weight per meter	15.7 kg (A-profile) or 14.7 kg (B-profile)
Material	steel AMVR1 / S355JR
Galvanizing of the steel and bolts	In accordance with EN ISO 1461 and EN 1179. For the beams alternatively: pre-galvanized material
Expected durability	Approx. 20 years, shorter in the case of more severe atmospheric corrosion exposure

3 Installation guidelines

3.1 General remarks

3.1.1 Place of installation

The system is a pile-driven guardrail system that has demonstrated the following performance classes in accordance with EN 1317-2:

- N2-W4-A

In choosing the place of installation the respective national regulations and the system performance, which resulted from the results of the crash tests according to EN 1317 (compare above: "technical data") are to be heeded.

According to regulations, the system can be used only if the available space behind the safety device is larger than the working width and / or is larger than the extremity lateral position of the vehicle on impact test according to EN 1317.

3.1.2 Limits of installation

General limits of installation cannot be specified because of varying local situations. Should the basic construction for any reason be deviated from because of the installation site, then the required changes should always take place in agreement with the contractee and the manufacturer.

In the execution of the installation the general known rules of engineering are to be observed

and adhered to.

3.1.3 Grounding

a. Soil class 1 and 2 in accordance with DIN 18300

The system is not suitable for this ground class and should not be installed under these conditions. An alternative would be to change the ground with suitable material.

b. Soil class 3 to 5 in accordance with DIN 18300

The system is suitable for this ground class and may be installed if the pile-driving time for each post does not exceed the times given in the table below and no deformation or damage to the heads of the posts occur, so that a flawless installation and functioning of the system is guaranteed. Damages to the hot dip galvanizing should be repaired in a technically correct manner. In the case that the posts are deformed or move from the correct position while pile-driving then proceed as in ground class 6/7.

System	Piling frame type	VR 100	VR 120	Hydraulic HRE 1000
	Power (Blows/min)	480	600	1000
	Energy (Nm)	420	480	770
EasyRail 1.33/2.00/4.00/6.00	Min	31 s	21 s	8 s
	Max	5,1 min	3,5 min	1,3 min
EasyRail OBB	Min	32 s	22 s	8 s
	Max	5,3 min	3,6 min	1,3 min
EasyRail XS 1.33/2.00/4.00	Min	21 s	15 s	6 s
	Max	3,5 min	2,4 min	0,9 min
EasyRail 3n	Min	19 s	13 s	5 s
	Max	3,1 min	2,2 min	0,8 min

c. Soil class 6 and 7 (DIN 18300) as well as with embedded cinder

In this case the post must be drilled. Posts needing to be shortened because of the condition of the ground may be undertaken only after written approval of the contractee and may not have a shorter pile-driven depth than 0,8 m.

Drilled holes are to be filled with appropriate material, followed by the pile-driving of the posts. If necessary, bitumen material is to be used for the sealing of drilled holes. Embedding the post in concrete is not permitted.

When pile-driving hindrances are encountered, beyond the defined soil class, special ar-

rangements need to be agreed upon.

3.1.4 Minimum installation length

The minimum installation length is specified above in Chapter 2 "Technical Data". Should the required tested length of the construction not be able to be met, the tested construction would then not meet the required system demands. With such a change of (shortened) construction, the construction in question should be agreed upon as a special onetime construction.

3.1.5 Permissible assembly temperatures

When the construction is taking place in Germany, it is not dependent upon the outside temperature at the time of the assembly. In regions where the minimum outdoor temperature T_{min} according to EN 1991-1-5/NA is under -24°C , the assembly may only take place with the written approval of the manufacturer.

3.1.6 Requirements for installation personnel

The construction is to be carried out exclusively by schooled and qualified personnel. The appointed installation team is to be led and watched over by a competent member with the appropriate expertise. Within Germany chapter 5.2.1 of ZTV-FRS 2013 applies. The installation personnel is to be equipped with their own personal protective gear according to the national requirements.

3.1.7 Control of the delivery / Labeling of the parts

The delivered system components are to be compared with the delivery note, examined for completeness, faults, damages at the construction site. Also the part lists in Appendix 1 are to be consulted.

Special components of the system (e.g. beams and posts) have the labeling mentioned in Appendix 2.

Damages, defects or wrong deliveries are to be reported immediately to the deliverer. Packaging material is to be disposed of according to the local rules and regulations.

3.1.8 Cable clarification

Before beginning construction, the contractor should be informed of the place and the running of cables, pipes, wires etc. In the area of the underground lines no pile-driving is allowed. It is also understood that the instructions of the cable owners are to be followed.

3.1.9 Traffic Safety

The construction zones are to be secured according to the requirements of the respective countries.

3.1.10 Personal protective gear or equipment

Protective and reflective clothing, according to the rules and regulations of the respective countries are to be worn at all times.

3.2 Installation

The installation of the system is to be carried out in general according to the diagram of the system in Appendix 3. The description in Appendix 4 can be referred to in relation to the installation process.

In the building up of stretches of the guard rails, damage to the galvanized surfaces are to be avoided. When setting the posts always use a post protection attachment. Hitting galvanized surfaces directly with a hammer is not permitted.

Small defects on the galvanized surface are to be touched up after careful preparation through the application of a suitable zinc dust coating according to EN ISO 1461.

With the installation (new and rebuilt), as well as with repair work on guard rail construction, only new bolting materials are to be used.

3.2.1 Installation heights in differing situations

The installation height averages as a rule 75 cm +3 cm. The installation height is measured from the top edge of the driving surface, when the distance between the front edge of the system and edge of the solid driving surface is not larger than 0.6 m and slope of the side area is not more than 12%. In the case that the distance between the front edge of the system and the edge of the solid driving surface is greater than 0.6 m, or if the shoulder has an inclination of more than 12%, the installation height is to be calculated directly from the system at the place of installation.

Curbs with a height difference of more than 7.5 cm are to be avoided. In the case that higher curbs already exist and cannot be removed, then the system can be adjusted locally as a untested special construction.

Proceed in the process as follows:

If at all possible place the system so that the front edge of the beam runs flush with the front edge of the curb. The installation height is then to be correlated to the top edge of the driving surface. With a distance > 30 cm to the front edge of the curb correlate the height of the guard rail beam to the top edge of the curb height.

Installation heights that differ from the given values should be coordinated with the contractee and require the written consent of the manufacturer.

3.2.2 Posts

The posts are to be inserted in the ground with an air or hydraulic pile driver and an appro-

appropriate striking attachment. The pile driver needs to have sufficient power or as the case may be enough driving pressure.

The posts are to be driven in vertically. Deviations of up to 7 cm on each side of the post over the area are permissible. In the case that there are objects in the ground that hinder the driving (e.g. rocks, roots etc.) it can happen that individual posts may become quite out of line or be twisted. If this should be the case with more than 20% of the posts, the corresponding soil class 6 and 7 procedure must be used to drill.

All posts have to be put with the closed side towards traffic.

The designated post distance (see Chapter 2 "Technical Data") may not be exceeded. In the case that a post cannot be set at the designated place because of adverse conditions at the construction site (cables, shafts, tunnels, tree roots, and the like) then it is to be set in the shortest possible distance from the designated position and an additional post is to be driven in the next "field".

3.2.3 Fittings

For a proper connection to be achieved, the screws should be set perpendicular in the connecting construction parts and are to be tightened according to regulations. The drilling tools need to be adjusted accordingly. When tightening the nuts, a washer should be placed under each nut to protect the zinc surface. Fishplates must not to be used to substitute washers.

For torques see the following table:

<i>Item No.</i>	<i>Bolt</i>	<i>Torque</i>
040.00	HRK (button head) Bolt with Nib M 16x27, 4.6 incl. Nut	70-140 Nm
040.01	HRK (button head) Bolt with Nib M 16x40, 4.6 incl. Nut	70-140 Nm
040.04	HRK (button head) Bolt with Nib M 16x45, 8.8 incl. Nut	70-140 Nm
040.40	Hex-head Bolt M 10x25, 4.6 incl. Nut	10-17 Nm (hand-tight)
040.43	Hex-head Bolt M 10x55, 8.8 incl. Nut	10-17 Nm (hand-tight)
040.43-2	Hex-head Bolt M 10x60, 4.6 incl. Nut	10-17 Nm (hand-tight)
040.54	Hex-head Bolt M 10x45, 8.8 incl. Nut	10-17 Nm (hand-tight)
040.54-1	Hex-head Bolt M 10x60, 8.8 incl. Nut	10-17 Nm (hand-tight)

The required tools for bolting are suitable socket wrenches or screw wrenches.

3.2.4 Support brackets

Spacers are generally to be built in perpendicular to the guard rail beams. Where by variances of possible shifting within the slots in the guard rail beams are permitted.

3.2.5 Beams

Beams with either profile A or B may be used. Where the beams connect, the overlap in principle is to be in the direction of traffic.

3.3 Deviations from the basic construction

The system is a straight running guard rail along level ground that has been tested according to EN 1317. Should there be a need to deviate from the basic construction in some way because of local conditions; this can only be done as an untested special construction that does not have the same qualities as the tested system. In any case this requires the approval of the contractee and the manufacturer.

In the execution of the installation the general known rules of engineering are to be observed and adhered to. Changes, which clearly lead to impairments to the functioning of the guard rail system are to be avoided.

In the case that subsequent work on the guard rail parts is necessary; no deviations from the standard parts should be performed, which could impair their way of functioning. This especially applies to the making of fitted parts (hole spacing, hole diameter, number of bolts, overlapping) and the shortening of posts. Cut edges are to be protected from corrosion with sufficient cold zinc coating

3.3.1 Fitted pieces

In order to make the length of the guard rail in accordance with local conditions, it may be necessary to install beams which are shorter in length than the standard building parts. These fitted pieces can be cut at the work site.

The following requirements are to be observed:

- Minimum length of 750 mm (profile overlapping 300 mm minimum)
- No exceeding of the given post spacing of the guard rail construction when installing.
- Cutting to length with a cutting machine or saw in a technically correct manner
- Drilling the holes of the bolt connections in a technically correct manner
- Touching up of the cut surfaces and the drilled holes of the bolt connections through the application of suitable zinc dust paint.

The installation of such fitted parts is to be reduced to a minimum. Only in exceptional cases (e. g. between two bridge structures) should fitted parts be installed.

In the case of particular building measures in medians such as vehicle crossings, tunnels or bridge structures, transitions to concrete barriers, etc. more than 1- 2 fitted parts between such measures should not be used.

The same applies to bridge structures. In this case, a maximum of 1 fitted part per stretch between 2 roadway crossings should be made. It is to be noted here that the guard rail beam

expansion joints may in no case be shortened.

In the case of maintenance and repair work it should be attempted to be done without any fitted parts, even when an increased effort for the mounting and dismounting of the undamaged connection ranges arises because of this.

Construction parts are only to be changed using drills and cutting machines in a technically correct manner. Work on the construction parts using welders, cutting devices, mandrel and striking and bending tools are not permissible.

3.3.2 Use of radii

With the installation of radius beams it should be heeded that they are built in without tension.

In the case of curves with radii < 30 m pre-bent beams (so-called radii beams) must be used. Radii beams are available in increments of 2.5 m:

25 m – 22.5 m – 20 m – 17.5 m – 15 m – 12.5 m – 10 m – 7.5 m – 5 m – 2.5 m

Convex radii beams should be used for outside curves and concave for inside curves. It is not permissible to bend the guard rail beams during installation at the work site to the point that permanent deformation occurs.

Especially with concave radii beams (inside curves) care must be taken, that the edge overlapping is not far apart when bolting together. It is recommended, that the edge overlapping is first bolted together and then afterwards fastening the beam to the spacers. Enlarging the holes, e. g. by means of reaming is not permissible.

Basically tight radii beams have to do with untested special constructions, which do not have the same characteristics as the tested guard rail system. In this case it is definitely necessary to obtain the permission of the contractee and the manufacturer.

3.3.3 Use of deviations

Deviations with an inclination of 1:20 – in exceptional cases of 1:12 – are permissible. When the beginning of the guard rail stretch occurs in the area of an ascending slope, the system can be shifted to the side and if an installation height not exceeding 85 cm is taken into account it can be embedded into the slope.

This also applies to a stretch of guard rail in the transition area in section/embankment. At the same time the designed post spacing (see Chapter 2 "Technical Data") must not be exceeded.

In the case that deviations need to be implemented on the basis of national regulations, then these national regulations take effect.

3.3.4 Additional attachments

Additional attachments may affect the performance of the system and therefore should not be installed. Particularly traffic signs must not be mounted directly to the system.

In any case additional attachments require a written approval of the manufacturer. Permission is deemed granted for the following attachments, provided that a loss of performance can be excluded:

- Attached guide posts, which can be mounted on posts.
- Attached guide posts, which can be mounted together with the joint-bolting on the beam. Deviating from the drawings the bolt M 16x45 HRK with a nose must be used at that place instead of the bolt M 16x30 HRK with a nose.
- Traffic signs, as long as no dangers come about because of them.
- Guard rail reflectors, which are attached to the beam with HRK bolts at the middle punched hole.
- Guard rail post sheathings according to TL-SPU

For the mounting of additional attachments (e.g. anti-glare shield, underride protection, etc.) a written consent of the manufacturer is required.

The attaching of traffic signs is not permitted. Traffic signs may be erected within the area of work, as long as on impact they bend over or break off.

3.4 Controls, self-monitoring reports, installation tolerances.

After installation the construction is to be tested with the aid of the general known rules of engineering and the self-monitoring reports in Appendix 5 in agreement with this manual. Adherence to staying within tolerances of installation should be particularly taken into account.

Compliance to installation tolerances, the fixed position of the bolted joints and the technically correct alignment of the stretches of guard rails are in particular to be heeded.

The installation tolerances are as follows:

<i>Measurement</i>	<i>Tolerance</i>
Spacing of the posts lengthwise	± 21 mm
Deviation of alignment of posts or beams	± 70 mm (see sketch)
Deviation of top edge of beam vertically	± 30 mm

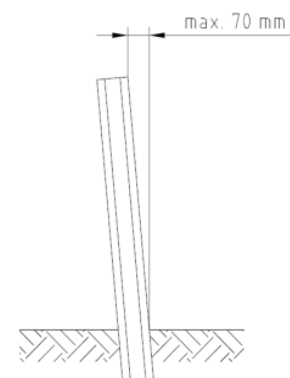

3.5 Repair, inspection and maintenance

As a basic principle all guard rail parts are to be replaced, which show obvious (plastic) permanent deformation.

When the parts of a considered stretch of guard rail are out of alignment up to approx. 30

cm, but not permanently deformed, then an alignment of the guard rail construction should be made.

In doing so corresponding and enlarged postholes are to be filled and sufficiently packed.

When damaged guard rails parts are replaced, special care must be taken when working in areas connected to the undamaged beams.

The beams remaining after removal may not be damaged (e.g. through the use of an angle grinder, mandrel or a hammer). Due to temperature determined length changes or larger sags from difficult drives to the building site, lengthwise hole patterns often do not coincide when connecting new beams with existing guardrails.

In the case that the distance between hole axes amounts to less than 5 cm, then the difference can usually be compensated for by the loosening of the bolts with several strikes. Otherwise proceed as follows.

As a general rule when repairs are undertaken in lower temperatures, the new beams are too short. The installation length between the post axes is greater than 4.00 m (e.g. 4.07 m), that is the overlapping amounts to less than 30 cm. This is not permissible.

As a result two fitted beam pieces must be cut in order to obtain an overall installation length > 4.00 m. (Example. 2.00 m + 2.07 m = 4.07 m). An additional post then needs to be set in order to not exceed the maximum spacing of the posts.

In the case of high temperatures or bigger sags the overlapping of the beams is as a general rule greater than 30 cm. In this case no fitted pieces need to be made. Instead new holes need to be drilled. This, however, is only permissible when the spacing between the new outer edges and the drilled holes is 40 mm or more.

As a basic principle however both fitted pieces and the drilling of new holes should be avoided, even when it means an additional effort through the removal or installation of adjoined sections.

Enlarged postholes in the shoulder of the road must be so packed that the newly rammed post is sufficiently stable. In the case that several damages at the same place due to accidents have occurred, then when necessary either the shoulder must be newly fortified or an additional post must be mounted if it is needed. This should be done in consultation with the contracting authority.

3.6 Reusability of guard rail parts

In the case of refitting and/or building alterations guard rail parts may be reused if:

- the building parts show no visible deformations and/or damages (e.g. torn out, reamed out or burned out holes)
- the zinc layer of hot-dip galvanised parts is 30 µm or more. Other zinc layers must show at least 50% of their original thickness.

- at labelled parts, the manufacturing identification and the test period identification can be clearly seen.

Materials for mounting (bolts, nuts, washers, Fishplates, connecting plates) that have already been built in at one time, may not be reused. New materials should always be used for installation. When repairing damages due to accidents only new materials may be used.

Construction parts that cannot be used any more, e.g. the cutting off of or the breaking up of parts, should be made unusable. So, too, the utilization of dismantled bolting materials should be applied to the corresponding national regulations.

3.7 Disposal / Recycling

Damaged building parts and building parts that cannot be used, are to be subjected completely to utilization / recycling or be installed in other areas of use (for example: farming, solar standing supports, private business)

3.8 Data for toxic substances

The individual guard rail components consist of 2 main building substances:

- steel
- zinc (hot dip galvanizing)

Both components are not toxic and are not in need of any special treatment or operation.

For on-site installation auxiliary substances are needed for the operation of machines and tools. For example these could be:

- diesel (e.g. compressor)
- pneumatic oil (e.g. operation of air pressure tools)
- gasoline (e.g. cutting off machine)
- grease or cutting paste (for the drilling of holes in guard rail parts)

In these cases the relevant data from the manufacturer and the requirements of the individual countries should be considered and heeded to.

3.9 Miscellaneous information

Because of its low height of 75 cm the system can be stepped over without any problem. Consequently there is no need to mount anything to assist in stepping over.

Appendix 1 - Parts List (4 m Section)

Easy-Rail 4.00, A profile, driven posts

Qty./4m	Order No.	Item	Weight
1	010.10	Fishplate M 10	0.200 kg
8	040.00	HRK (button head) Bolt with nib M 16x27, 4.6 incl. Nut; ISO 4032-5	0.100 kg
8	040.30	Washer Ø 18, DIN 126	0.010 kg
1	040.43-2	Hex head Bolt M 10x60 Mu, 4.6	0.050 kg
1	040.60	Washer Ø 11, DIN 126	0.004 kg
1	301.00	Safety Barrier Beam, A profile, t=2.5mm	37.000 kg
1	303.00	Post C-100-60-25, 1.750 mm	16.500 kg
1	304.00	Support Bracket, A profile, 6° inclination	1.200 kg

Easy-Rail 4.00, B profile, driven posts

Qty./4m	Order No.	Item	Weight
1	010.10	Fishplate M 10	0.200 kg
6	040.00	HRK (button head) Bolt with nib M 16x27, 4.6 incl. Nut; ISO 4032-5	0.100 kg
6	040.30	Washer Ø 18, DIN 126	0.010 kg
1	040.43-2	Hex head Bolt M 10x60 Mu, 4.6	0.050 kg
1	040.60	Washer Ø 11, DIN 126	0.004 kg
1	302.00	Safety Barrier Beam, B profile, t=2.5mm	37.000 kg
1	303.00	Post C-100-60-25, 1.750 mm	16.500 kg
1	304.10	Support Bracket, B profile, 6° inclination	1.200 kg

Appendix 2 - Marking of Parts

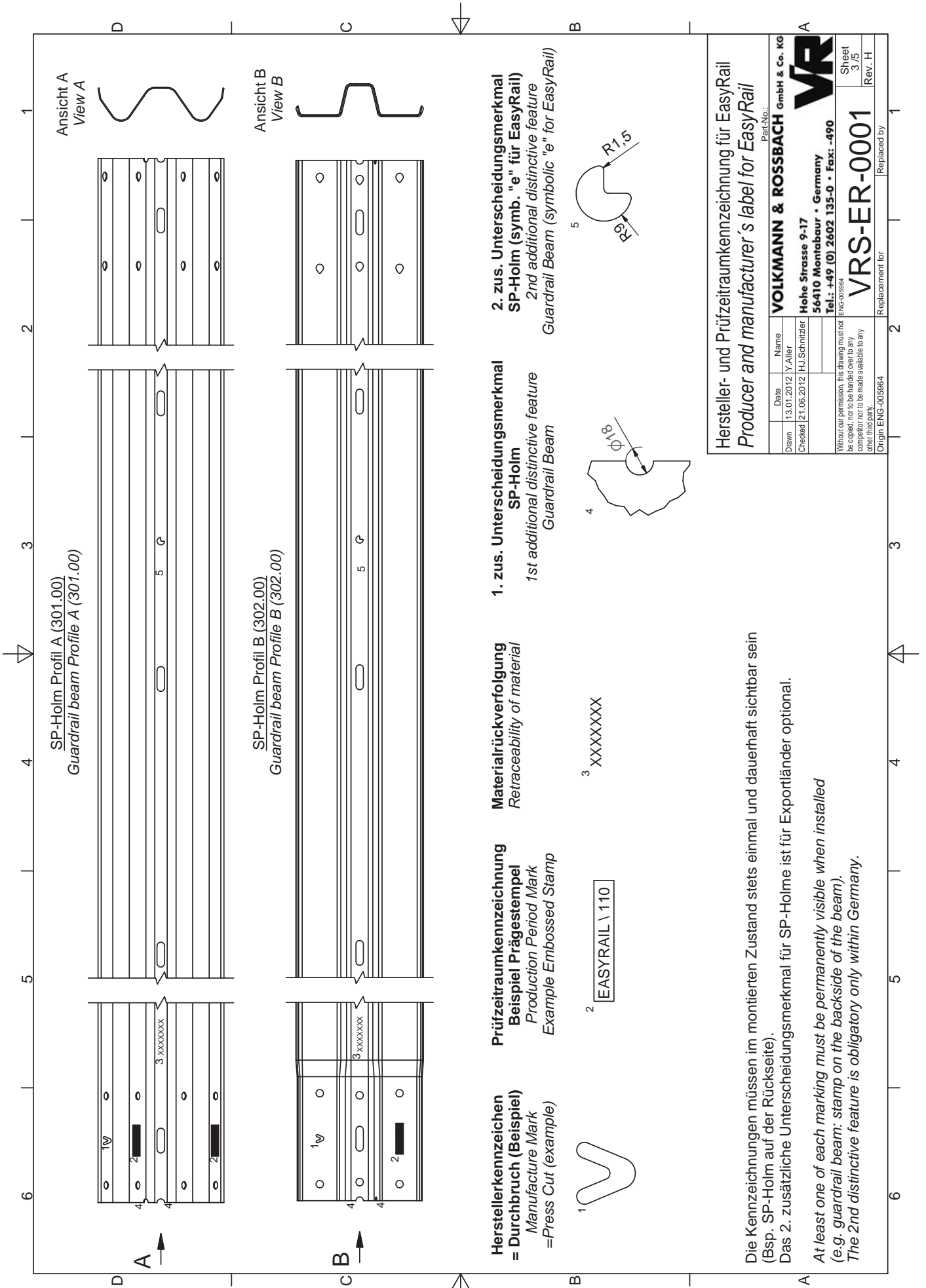

Die Kennzeichnungen müssen im montierten Zustand stets einmal und dauerhaft sichtbar sein (Bsp. SP-Holm auf der Rückseite).
Das 2. zusätzliche Unterscheidungsmerkmal für SP-Holme ist für Exportländer optional.

At least one of each marking must be permanently visible when installed (e.g. guardrail beam: stamp on the backside of the beam).
The 2nd distinctive feature is obligatory only within Germany.

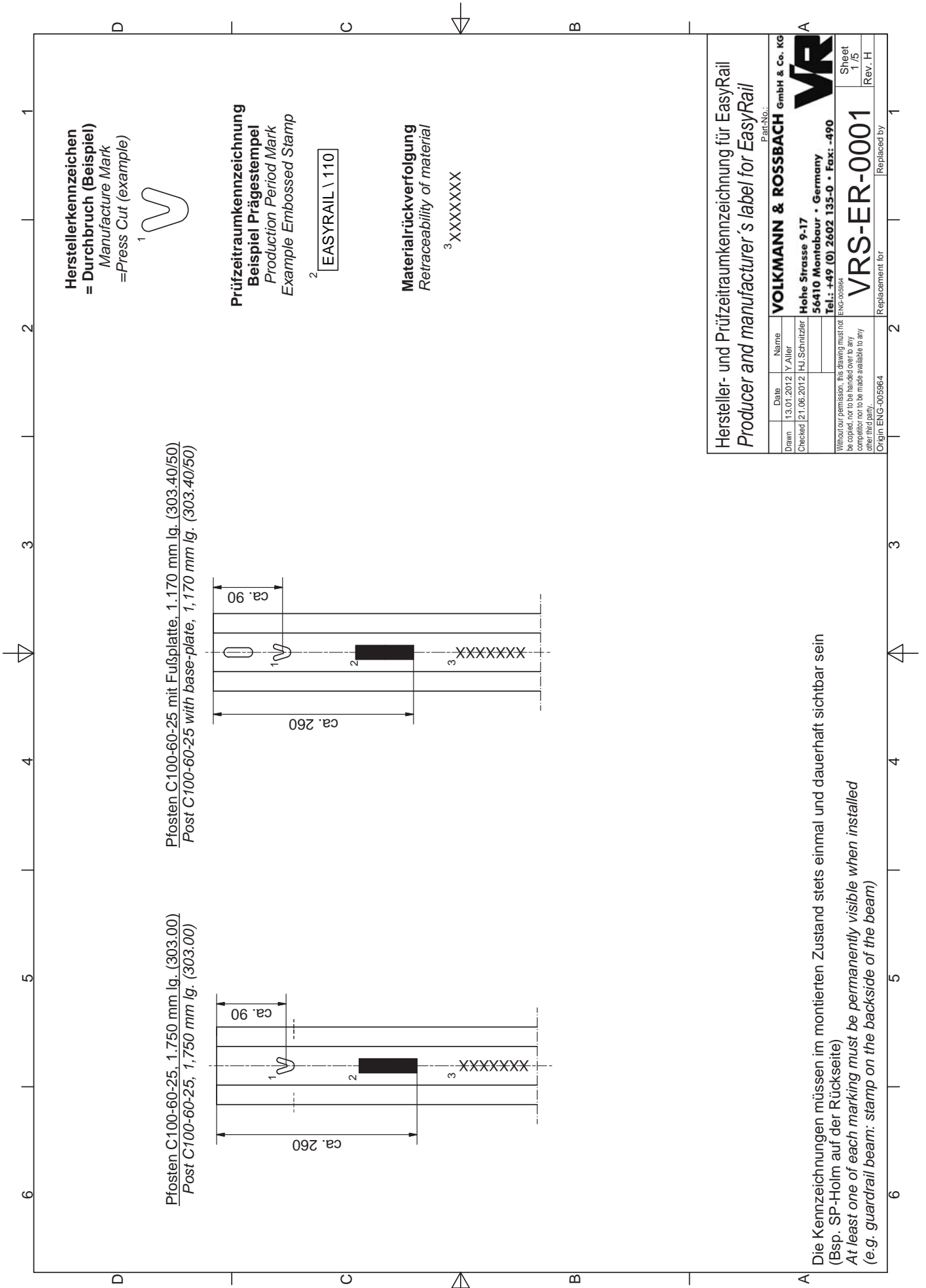

Herstellerkennzeichen
 = Durchbruch (Beispiel)
 = Manufacture Mark
 = Press Cut (example)



Prüfzeitraumkennzeichnung
 Beispiel Prägestempel
 = Production Period Mark
 = Example Embossed Stamp

EASYRAIL \ 110

Materialrückverfolgung
 = Retraceability of material
 XXXXXXXX

Pfosten C100-60-25 mit Fußplatte, 1.170 mm lg. (303.40/50)
Post C100-60-25 with base-plate, 1.170 mm lg. (303.40/50)

Pfosten C100-60-25, 1.750 mm lg. (303.00)
Post C100-60-25, 1.750 mm lg. (303.00)

Hersteller- und Prüfzeitraumkennzeichnung für EasyRail
Producer and manufacturer's label for EasyRail

Date	Name
13.01.2012	Y. Aller
Checked 21.06.2012	HJ. Schmitzler

Without our permission, this drawing must not be copied, nor be handed over to any competitor nor be made available to any other third party.
 Origin: ENG-005864

VOLKMANN & ROSSBACH GmbH & Co. KG
 Hohe Strasse 9-17
 56410 Montabaur · Germany
 Tel.: +49 (0) 2602 135-0 · Fax: -490

VR
 Sheet 1/5
 Rev. H

VRS-ER-0001
 Replacement for

Die Kennzeichnungen müssen im montierten Zustand stets einmal und dauerhaft sichtbar sein
 (Bsp. SP-Holm auf der Rückseite)
 At least one of each marking must be permanently visible when installed
 (e.g. guardrail beam: stamp on the backside of the beam)

Freigegebene Hersteller und Herstellerkennzeichen für EasyRail
Approved producer and manufacture labeling for EasyRail

Stand/date: 24.07.2012

VOLKMANN & ROSSBACH GmbH & Co KG
 Hohe Straße 9-17
 56410 Montabaur

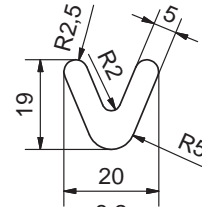

**BBV Baustahl und Blechverarbeitungs-
 gesellschaft mbH & Co. KG**
 Am Lokwerk 11
 14774 Brandenburg

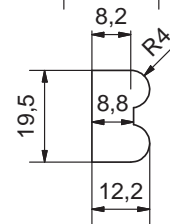

KFS Kirchmöser Formstahl GmbH
 Am Lokwerk 11
 14774 Brandenburg

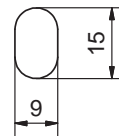

ERWIN PEETZ GmbH & Co. KG
 Finkenstrasse 14
 57368 Lennestadt

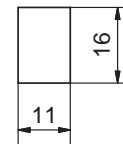

ISKOOR Metals & Steel Ltd.
 Industrial Area B
 P.O. Box 555
 Ramla 72104
 Israel

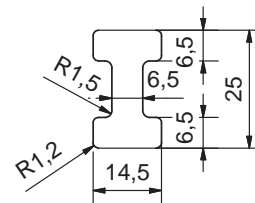

SPIG Schutzplanken-Produktions GmbH
 Schmelzer Straße 7
 66839 Schmelz-Limbach

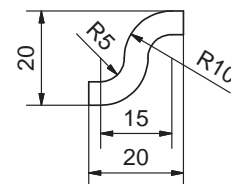

Hersteller- und Prüfzeitraumkennzeichnung für EasyRail
Producer and manufacturer's label for EasyRail

Part-No.:			VOLKMANN & ROSSBACH GmbH & Co. KG	
Drawn	13.01.2012	Y.Aller	Hohe Strasse 9-17	
Checked	21.06.2012	H.J.Schnitzler	56410 Montabaur · Germany	
			Tel.: +49 (0) 2602 135-0 · Fax: -490	
Without our permission, this drawing must not be copied, nor to be handed over to any competitor nor to be made available to any other third party.			VRS-ER-0001	
Origin ENG-005964			Replacement for	Replaced by



Sheet
5 / 5
Rev. H

Appendix 3 - Drawings

System Drawing (A-Profile)

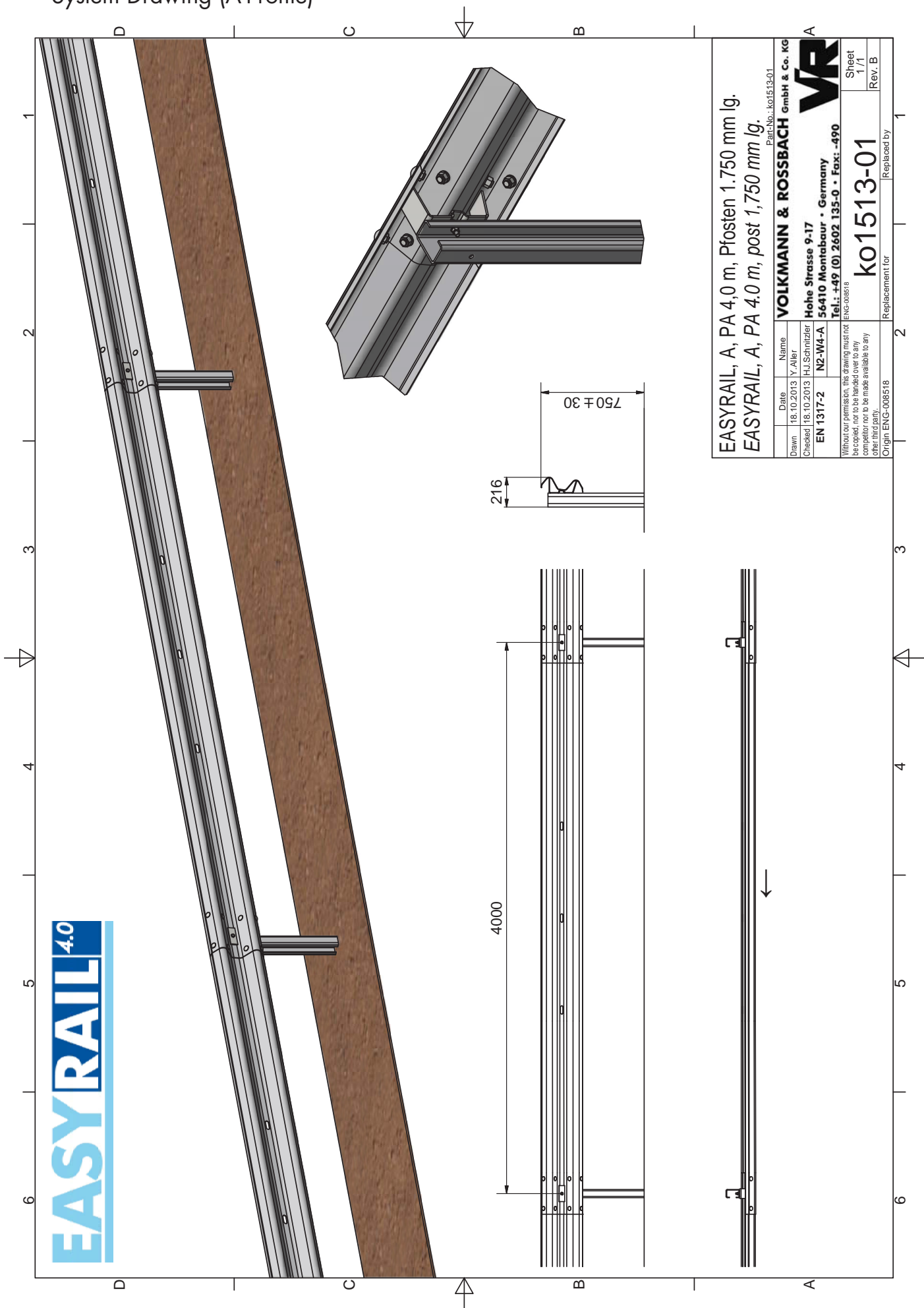

EASYRAIL^{4.0}

EASYRAIL, A, PA 4,0 m, Pfosten 1.750 mm lg.
EASYRAIL, A, PA 4,0 m, post 1,750 mm lg.

Drawn	18.10.2013	Name	H-J.Schmitzler
Checked	18.10.2013	Yr.-Aller	H-J.Schmitzler
EN 1317-2		N2-W4-A	

Without our permission, this drawing must not be copied, nor to be handed over to any competitor nor to be made available to any other third party.
 Origin ENG-008518

Part-No.: K01513-01

VOLKMAN & ROSSBACH GmbH & Co. KG
 Hohe Strasse 9-17
 56410 Montabaur · Germany
 Tel.: +49 (0) 2602 135-0 · Fax: -490
 ENG-008518

VR

Sheet 1/1
 Rev. B

K01513-01

Replacement for
 Replaced by

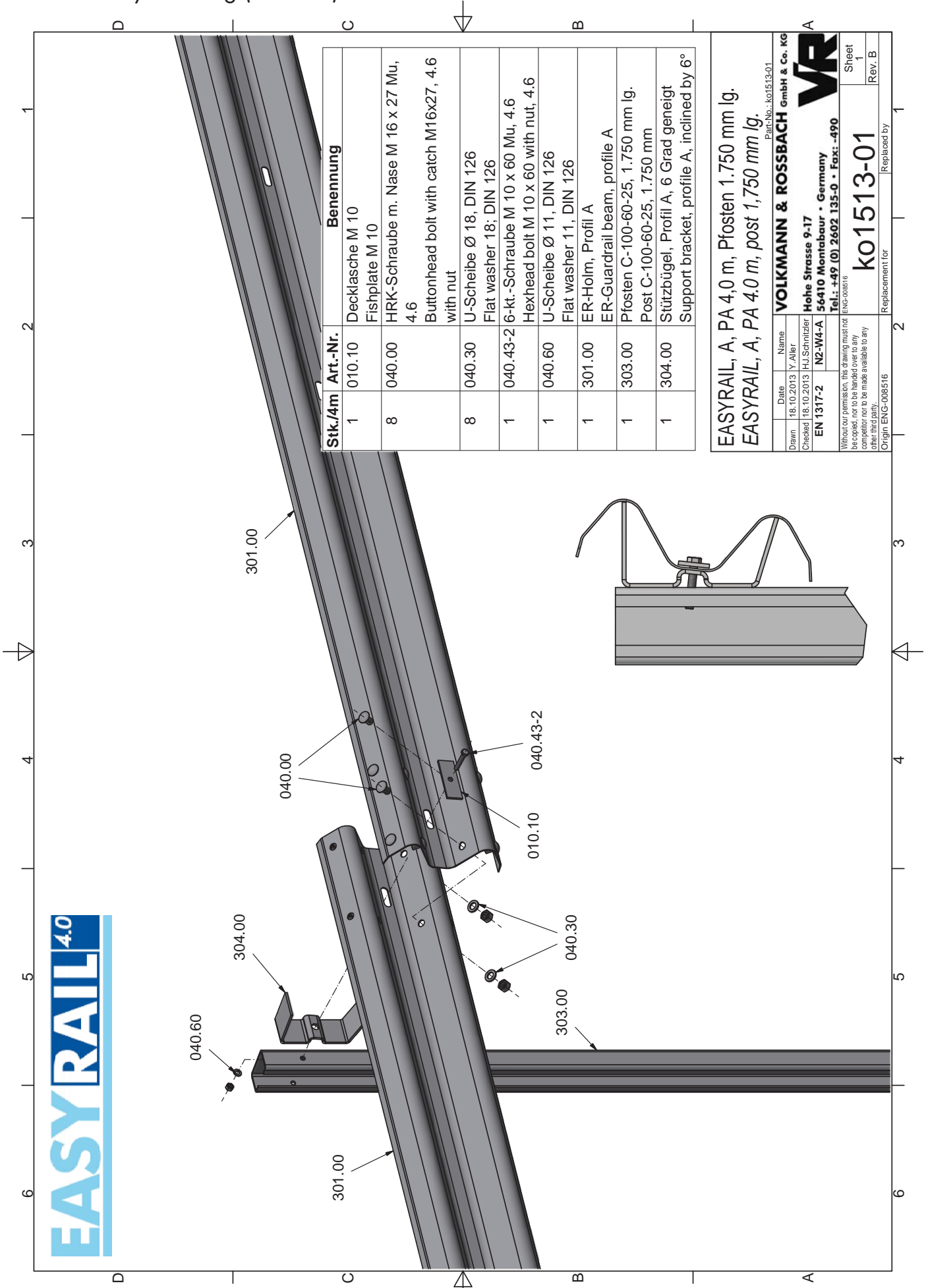

Stk./4m	Art.-Nr.	Benennung
1	010.10	Decklasche M 10
		Fishplate M 10
8	040.00	HRK-Schraube m. Nase M 16 x 27 Mu, 4.6
		Buttonhead bolt with catch M16x27, 4.6 with nut
8	040.30	U-Scheibe Ø 18, DIN 126
		Flat washer 18; DIN 126
1	040.43-2	6-kt.-Schraube M 10 x 60 Mu, 4.6
		Hexhead bolt M 10 x 60 with nut, 4.6
1	040.60	U-Scheibe Ø 11, DIN 126
		Flat washer 11, DIN 126
1	301.00	ER-Holm, Profil A
		ER-Guardrail beam, profile A
1	303.00	Pfosten C-100-60-25, 1.750 mm lg.
		Post C-100-60-25, 1.750 mm
1	304.00	Stützbügel, Profil A, 6 Grad geneigt
		Support bracket, profile A, inclined by 6°

EASYRAIL, A, PA 4,0 m, Pfosten 1.750 mm lg.
EASYRAIL, A, PA 4,0 m, post 1,750 mm lg.

Part No.: ko1513-01

VOLKMANN & ROSSBACH GmbH & Co. KG
 Hohe Strasse 9-17
 56410 Montabaur · Germany
 Tel.: +49 (0) 2602 135-0 · Fax: -490

EN 1317-2 N2-W4-A
 H-J.Schmitzler

Without our permission, this drawing must not be copied, nor to be handed over to any competitor nor to be made available to any other third party.
 Origin: ENG-008516

Replacement for **KO1513-01** Replaced by

Sheet 1
 Rev. B

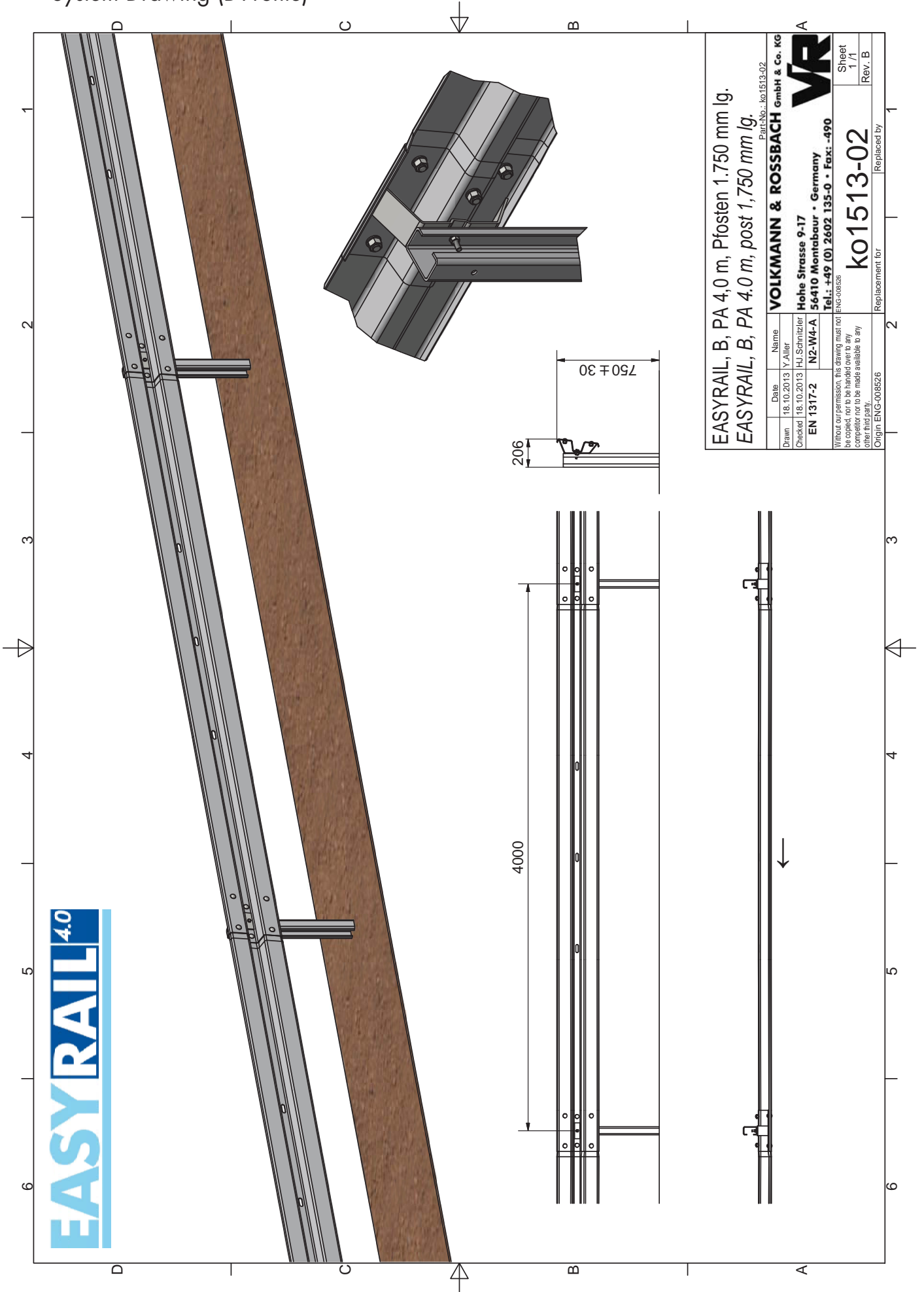

EASYRAIL^{4.0}

EASYRAIL, B, PA 4,0 m, Pfosten 1.750 mm lg.
EASYRAIL, B, PA 4.0 m, post 1,750 mm lg.

Part No.: KO1513-02

VOLKMANN & ROSSBACH GmbH & Co. KG
 Hohe Strasse 9-17
 56410 Montabaur · Germany
 Tel.: +49 (0) 2602 135-0 · Fax: -490

EN 1317-2 N2-W4-A

Without our permission, this drawing must not be copied, nor be handed over to any competitor nor to be made available to any other third party.
 ENG-008526

Origin ENG-008526

Replacement for **KO1513-02**

Replaced by

Sheet 1/1
 Rev. B



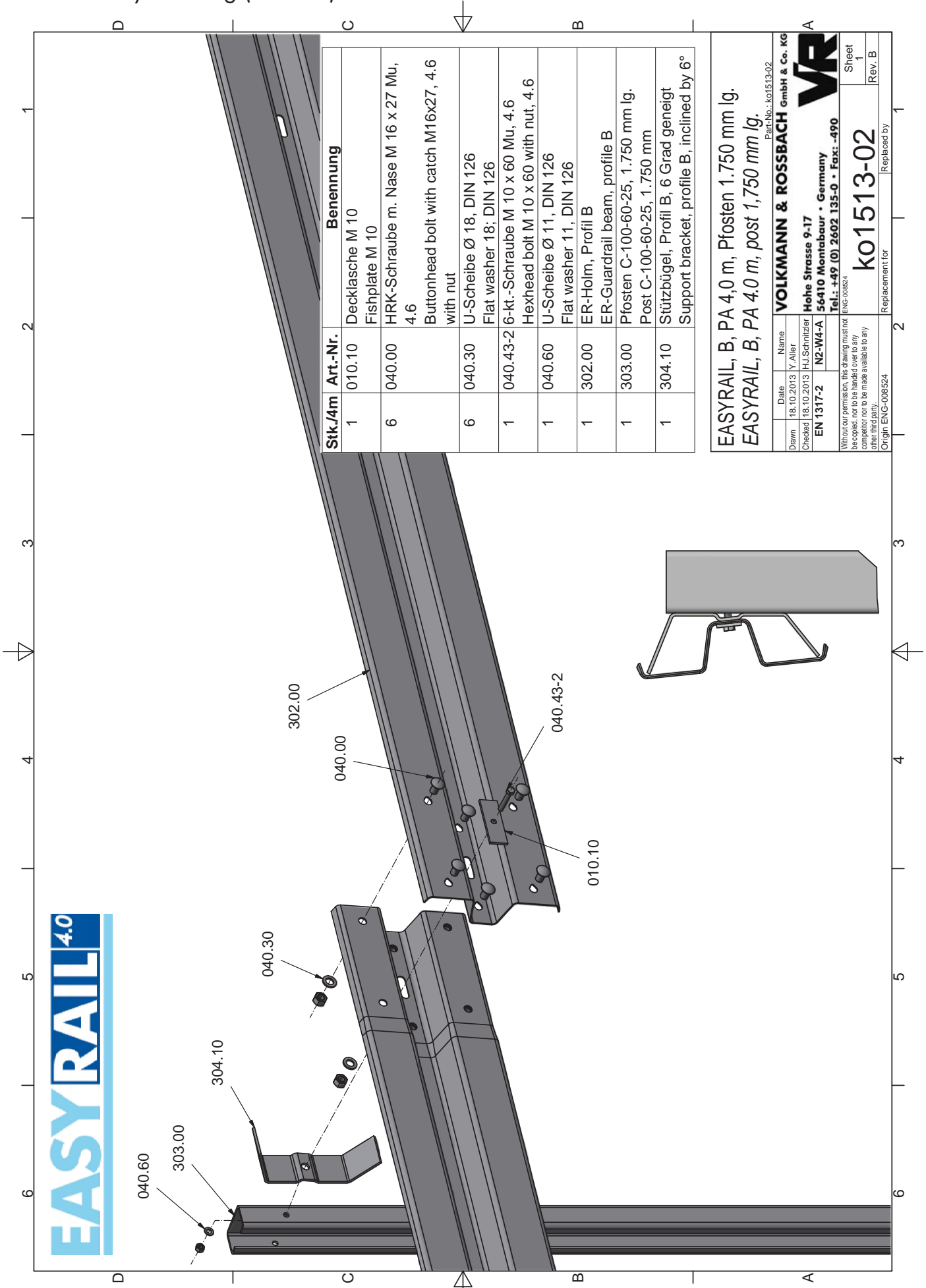

Stk./4m	Art.-Nr.	Benennung
1	010.10	Decklasche M 10
		Fishplate M 10
6	040.00	HRK-Schraube m. Nase M 16 x 27 Mu, 4.6
		Buttonhead bolt with catch M16x27, 4.6 with nut
6	040.30	U-Scheibe Ø 18, DIN 126
		Flat washer 18; DIN 126
1	040.43-2	6-kt.-Schraube M 10 x 60 Mu, 4.6
		Hexhead bolt M 10 x 60 with nut, 4.6
1	040.60	U-Scheibe Ø 11, DIN 126
		Flat washer 11, DIN 126
1	302.00	ER-Holm, Profil B
		ER-Guardrail beam, profile B
1	303.00	Pfosten C-100-60-25, 1.750 mm lg.
		Post C-100-60-25, 1.750 mm
1	304.10	Stützbügel, Profil B, 6 Grad geneigt
		Support bracket, profile B, inclined by 6°

EASYRAIL, B, PA 4,0 m, Pfosten 1.750 mm lg.
EASYRAIL, B, PA 4,0 m, post 1,750 mm lg.

Part No.: ko1513-02

VOLKMANN & ROSSBACH GmbH & Co. KG
 Hohe Strasse 9-17
 56410 Montabaur • Germany
 Tel.: +49 (0) 2602 135-0 • Fax: -490

EN 1317-2 N2-W4-A
 H-J.Schmitzler

Without our permission, this drawing must not be copied, nor to be handed over to any competitor nor to be made available to any other third party.
 Origin: ENG-008524

Replacement for **ko1513-02** Sheet 1 Rev. B

Easy-Rail Support Brackets are available in two versions. Both versions can be used equivalently.

1. Support Bracket No. 304.00 for A-Profile, 6° inclination

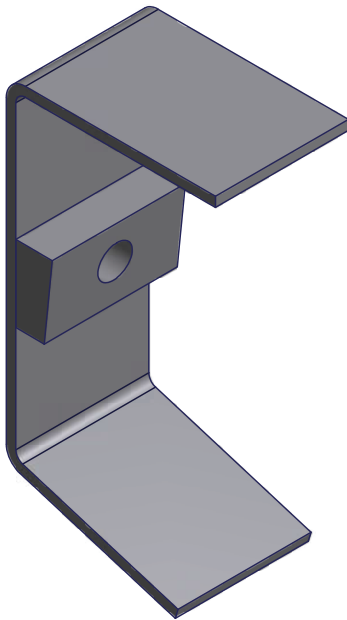

Version 1

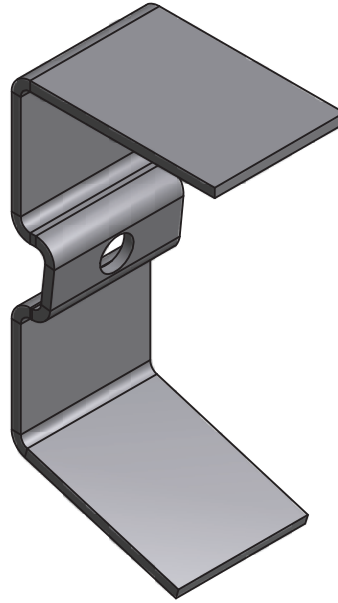

Version 2

2. Support Bracket No. 304.10 for B-Profile, 6° inclination

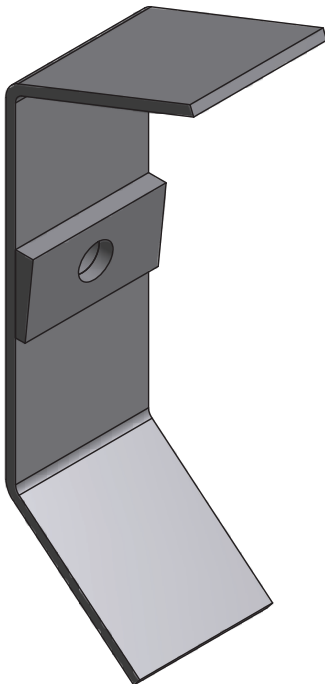

Version 1

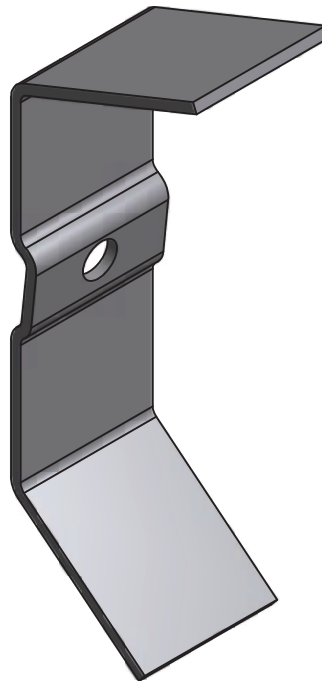

Version 2

Appendix 4 - Assembly Instructions *

Assembly of the components according to the drawings of Appendix 3.



1. Test Track pre installation



2. Laying out the beams



3. Aligning beams ...



4. ... for piling frame



5. Laying outposts and brackets



6. Preparing of pile driver

* Sample System: Easy-Rail 1.33 (Post Distance 1.33m)



7. Driving posts into ground



8. Pre Mounting brackets and beams



9. Mounting of system step by step



10. completed EASY RAIL



10. Connection details



11. Rear side of system

Appendix 5 - Form for Internal Quality Control

Self Monitoring Report – EasyRail

Customer	Contractor (Stamp)
Project-Nr.	
Work Site	
Vehicles	

Team Leader	Team Member 2
Team Member 3	Team Member 4
Team Member 5	Team Member 6

No.	Achievement /Product	Linear Metres	Pieces	Hours
1				
2				
3				
4				
5				
6				
7				
8				
9				
10				

Consecutively use these marks: + = ok, o = not ok, - = not inspected

<input type="checkbox"/> All system parts installed according to manual?	<input type="checkbox"/> Beam joints overlapping in direction of traffic? Overlapping 30 cm minimum (fitting parts)?
<input type="checkbox"/> Closed side of posts to traffic? Post distance correct?	<input type="checkbox"/> Support brackets installed with correct orientation?
<input type="checkbox"/> All fishplates installed?	<input type="checkbox"/> All screws and washers installed? Screwing torques correct?
<input type="checkbox"/> Minimum lengths of fitting parts 750 mm?	<input type="checkbox"/> Minimum distance of drilled joint holes to beam end 40 mm? Minimum diameter of drilled holes 18 mm?
<input type="checkbox"/> No posts shortened? None of the existing holes widened?	<input type="checkbox"/> System aligned laterally and heightwise?
<input type="checkbox"/> System identification stickers put (where required)?	

Name and Signature Contractor	Name and Signature Customer
-------------------------------	-----------------------------